

8 7 6 5 4 3 2 1

Direction of Rotation

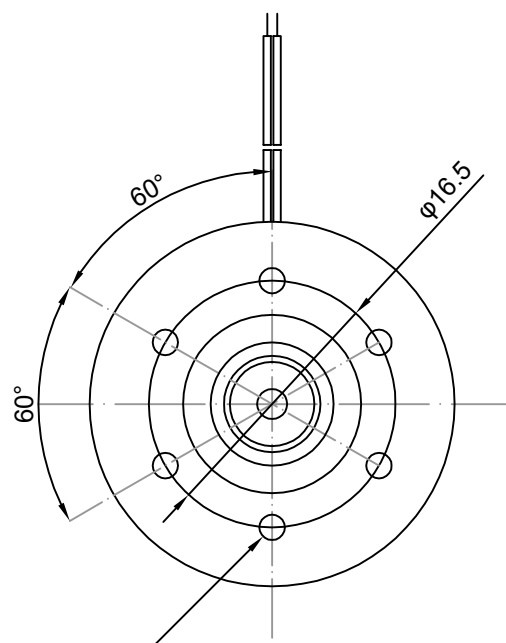

JIS M1.7x0.35 TAPPED HOLE 6 PLACES

- Notes:
 1. Male screw length 1.1 max.
 2. Allowable torque for screw of tapped hole: 2.0 Kgf-cm

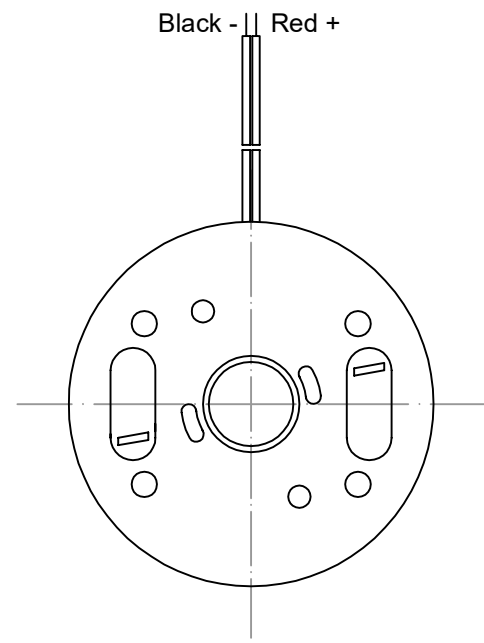
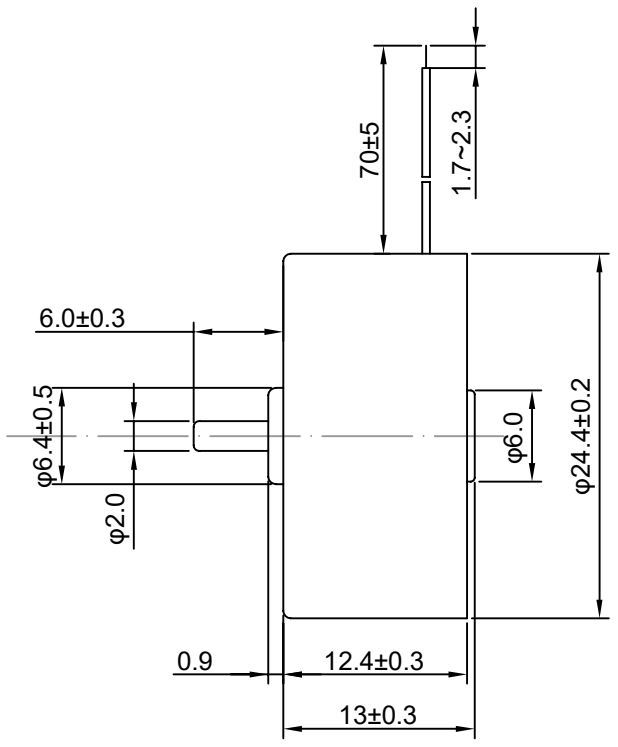

No.	Item	Specification	No.	Item	Specification
1	Rated Voltage	3V DC	7	Rated Load	4.0g.cm
2	Voltage Range	1.0-5.0V DC	8	Starting Voltage	0.6V (No Load)
3	No Load Current	35mA Max	9	Motor Resistance	11ohm±12%
4	No Load Speed	3700±10%RPM	10	Shaft end play	0.05-0.25mm
5	Rated Load Current	100mA Max			
6	Rated Load Speed	2700±10%RPM			

Drawn	Tony	09/26/2024	Unit: mm	
Checked	Eva	09/26/2024	Kysan Electronics www.kysanelectronics.com	
Eng Appr.				
Mfg Appr.				
Q.A.				
SKU: 1112002			Siae: A4	Weight(Kg):
			Scale	

8 7 6 5 4 3 2 1

A

A