

Rev.	Description	Date
01	Release for Production	06/17/2014

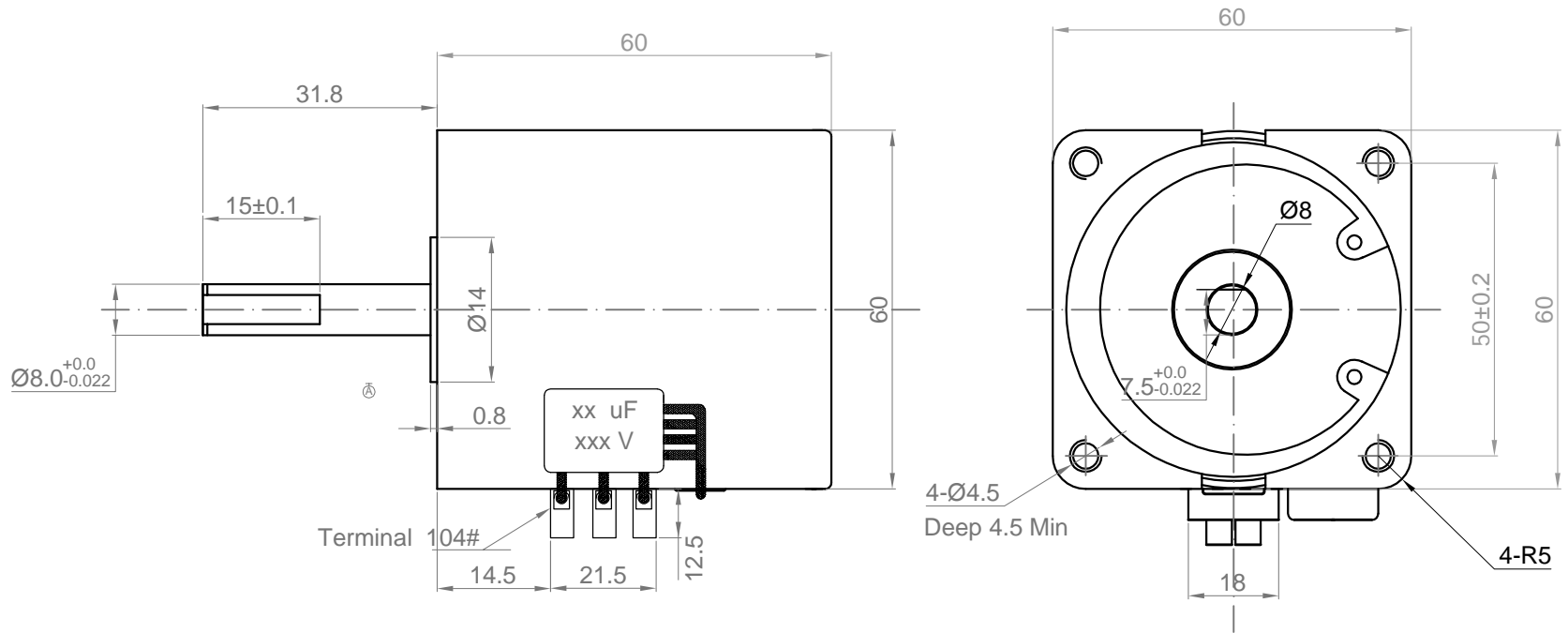

The technical requirements

1. The motor surface should not have damage defects such as scratches and bruises.
2. The motor operates without a murmur.
3. The motor after clamping no bad defects such as loose, fall off.
4. Motor reducer steady load should be less than 30 biggest KGF. Cm.
5. Static moment project inspection "as required by the customer.

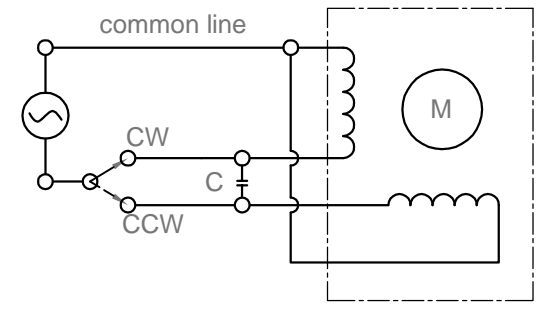

NO.	Item	Specification	NO.	Item	Specification
1	Frequency	50/60HZ	7	Input Current	110≤mA / ≤55mA
2	Voltage	110/220 VAC	8	Insulation Class	E
3	Torque	15/12 kgf·cm	9	Insulation Resistance	≥100MΩ
4	Speed	10/12 RPM			
5	Direction of rotation	CW、CCW			
6	Capacitance	1 / 0.27uF			

Drawn	L	11/1/2015	Kysan Electronics www.kysanelectronics.com info@kysanelectronics.com		
Checked					
Eng Appr.					
Mfg Appr.					
Q.A.					
SKU	1311034		Size : A4	Weight(Kg): 0.34	Unit: mm
			Scale: 2:1		Sheet 1of 1